



# A Profitable Transition Away from Isolation and Mercury Use in ASM

*Kevin Telmer, Artisanal Gold Council, University of Victoria*



*Mozambique, 2009*

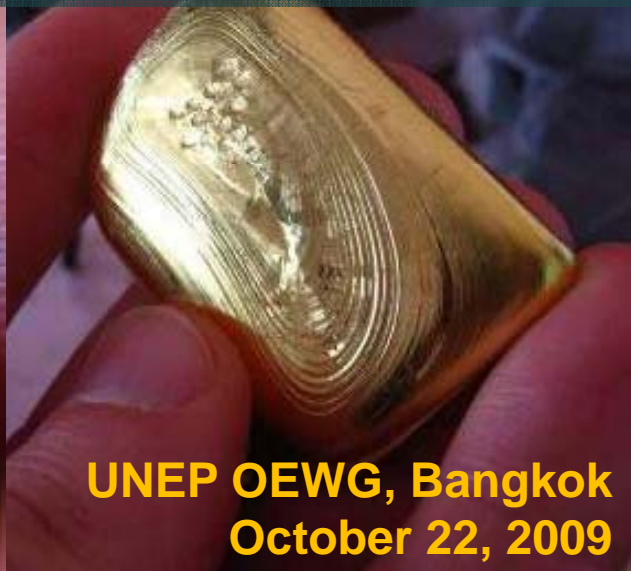

**UNEP OEWG, Bangkok  
October 22, 2009**

# Outline

- Gold and Mercury
  - Extent and Causes
- Solutions
  - Technology Transfer
  - Financial Mechanisms
  - Enabling Policy
  - Control of Supply; Higher Mercury Price
- Reduction Scenarios

# ASM Gold in Poverty Relief

- Artisanal and Small Scale Gold Mining (ASGM) – a superb development opportunity
  - Excellent for transferring wealth from rich to poor countries
  - Small miners often get 70% or more of international price in remote areas; not true for any other product
  - BUT: often involves mercury use
- Improved practices and reputation needed to make this important opportunity sustainable
- **Reducing mercury use is key to realizing this opportunity as well as to reducing global mercury pollution**

# How Important is ASGM?

## Scale and Economy

- 330 tonnes of gold from 70 countries (12% total gold)
- 10 billion USD at 900\$/ozt
- 10 million miners (3 million women and children)
- Secondary economy, perhaps 50 million people at 50 billion USD/a

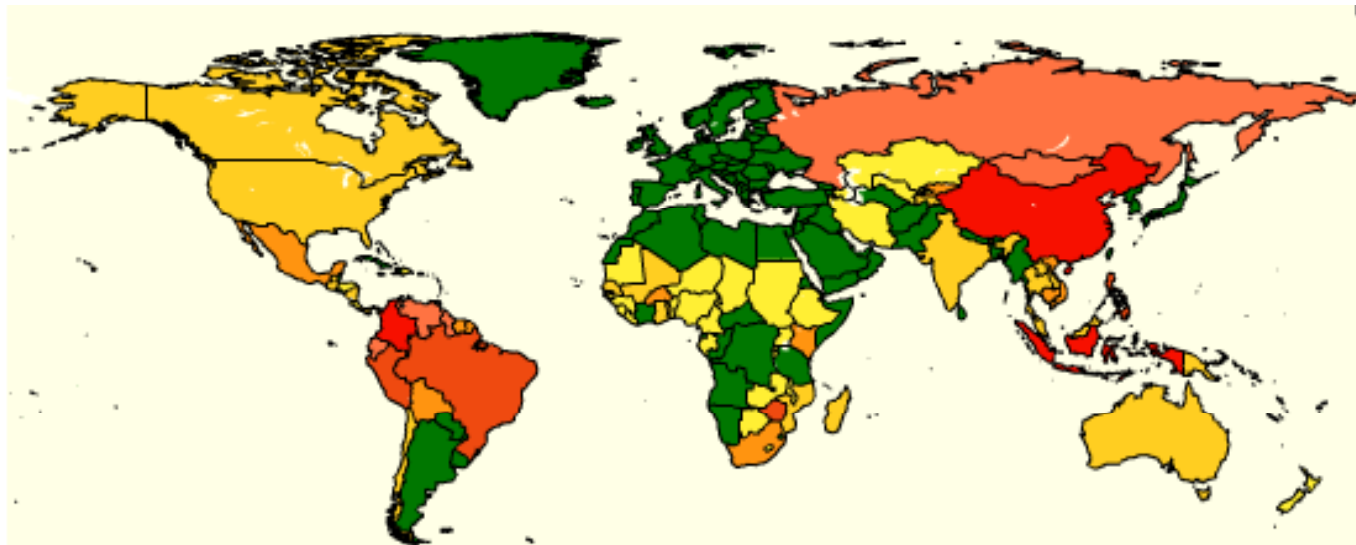

# Mercury Watch Database; AGC + UNEP

[www.mercurywatch.org](http://www.mercurywatch.org)

Home About Us Contact Us Login Register

Mercury **Hg** Watch

Charting the improvement of artisanal small-scale gold mining

Global Database Research Paper

Mean AGSM Hg Per Year

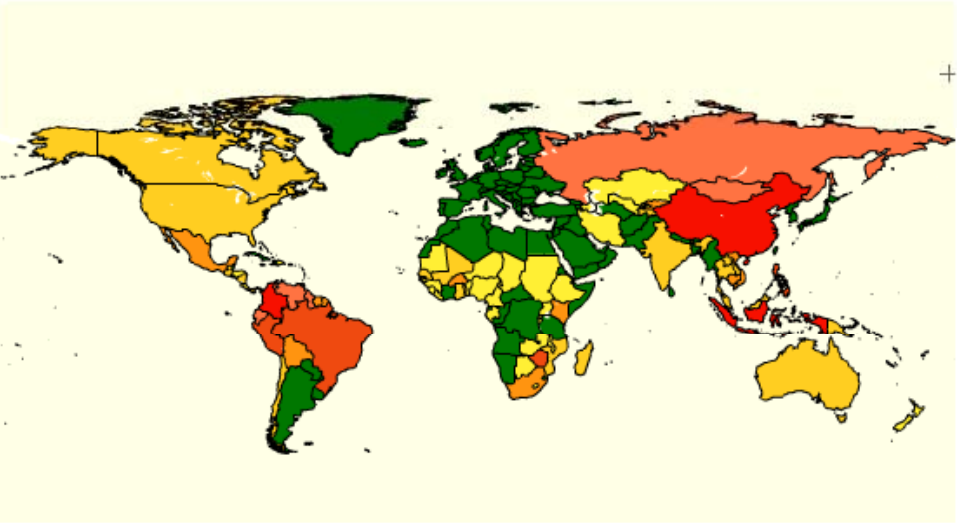

**Mercury Emission from ASGM (tons/a)**

- no estimate made
- 0 to 1
- 1 to 5
- 5 to 10
- 10 to 25
- 25 to 50
- 50 to 500



**Welcome to MercuryWatch Beta Site - August 2009**  
Mercury Watch is dedicated to collecting, analysing, and publically serving information about mercury released to the environment.

**Artisanal and Small-Scale Gold Mining (ASGM)** has become the world's largest 'direct use' emitter of mercury to the environment. In spite of this, a global database of the distribution of ASGM and mercury-use does not exist. This

**MercuryWatch call for partners:**

The breadth of society that interacts with Artisanal and Small Scale Gold Mining (ASGM) is much broader than is generally recognized. This, along with the global growth in ASGM underway makes it a significant issue for governments and society. This requires that they work harder towards making the sector safer, socio-economically sustainable and less detrimental to the environment. MercuryWatch is committed to these goals and is seeking

# Mercury Released to Environment from ASM (2008)

- 1000 tonnes/year released
  - 2009 estimates are likely to be more
- 1/3 anthropogenic releases, 2nd only to coal burning
- 400 tonnes/year emitted to the atmosphere
- 600 tonnes discharged into soils, rivers and lakes
  - Telmer and Veiga (2008) in: Global Mercury Emissions to the Atmosphere from Natural and Anthropogenic Sources, ISBN: 978-0-387-93957-5 <http://www.springerlink.com/content/1056370251581180/>
  - Or <http://www.mercurywatch.org/default.aspx?panename=researchPaper>

# How is Mercury Used and Lost?

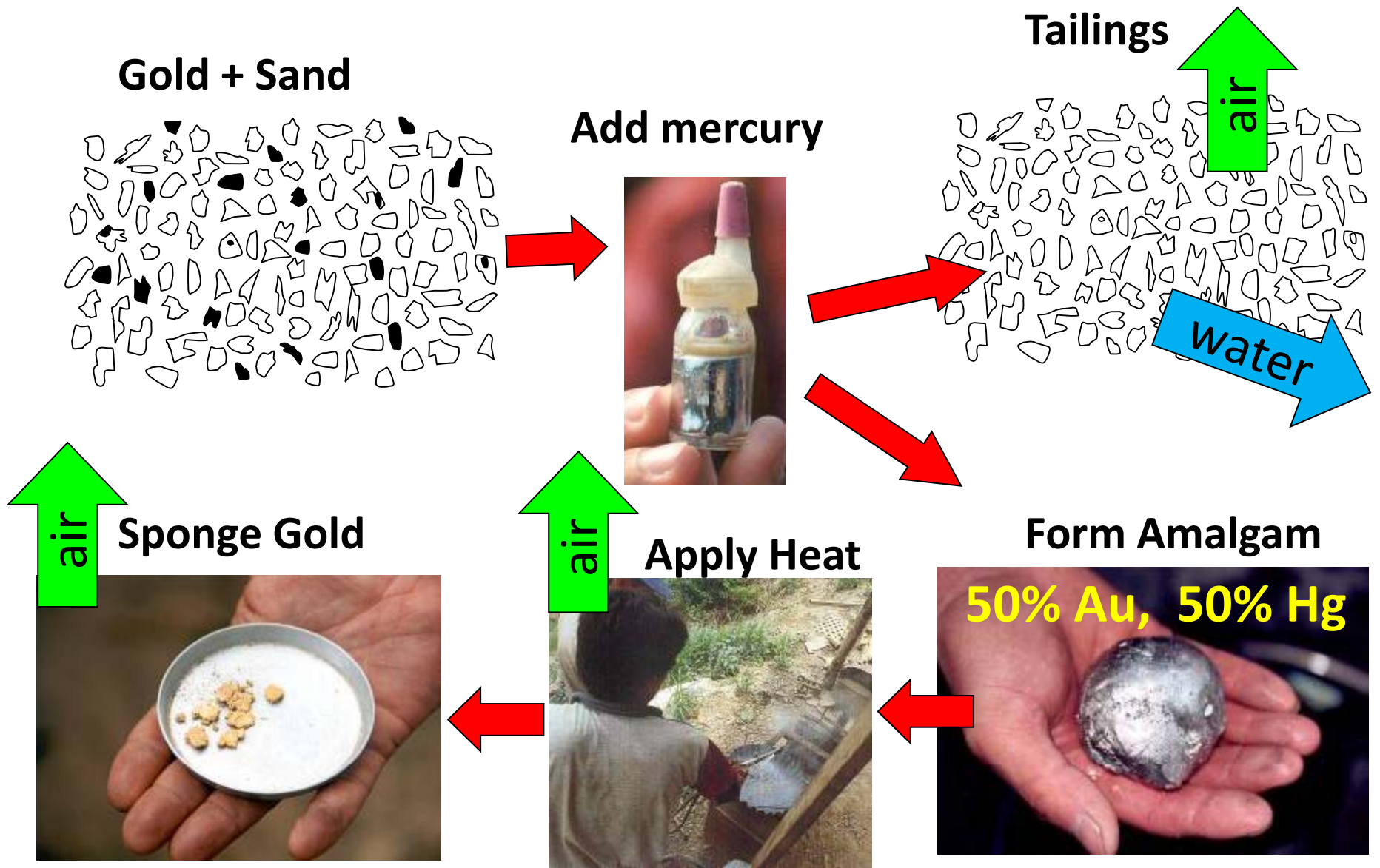

# Typical Method



# Why is Mercury Used?

- Very easy
- Very independent – 1 person can do it
- Highly effective under field conditions
- Accessible
- Cheap:
  - Jan 22, 2008, mercury US\$0.017/g; gold US\$28/g
  - **1:1650**
  - (local prices are different)
  - Worst prices 1:125 – still cheap
- Facilitates precise transactions
- Produces quick capital (1 day)
- Divides profits
- Miners are not aware of the risks
- No choice



# Solutions

- Technological
- Financial/ market
- Policy

# Technical Solutions

- Alternative processing
  - Zero mercury
  - Lower mercury
- Mercury Recycling
  - emissions control (fume hoods, retorts)
  - mercury re-activation
- Widespread education needed about these methods
- Local innovation often critical to adapt methods

# Education !



# Mercury Losses Vary With Process

## *Whole Ore Amalgamation*

**BAD**

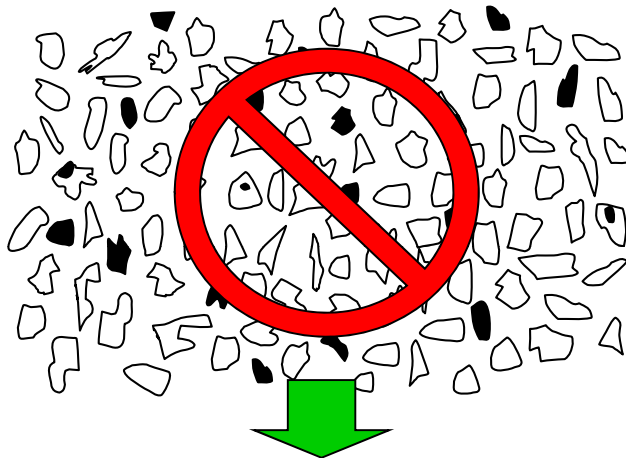

Preliminary Gravity  
Concentration



## *Concentrate Amalgamation*

**BETTER**



- Much more mercury lost when **whole ore** is amalgamated
- Even worse when CN is used after mercury – a growing trend



Gold loss to Tailings  
*Technologically Solvable*



# High intensity whole ore amalgamation



# High intensity whole ore amalgamation



# Alternative Processing: Concentrate Amalgamation



**Mercury is added only to a small amount of material (a gravity concentrate), losses are much less**



# Emission Control Example: Fume Hoods



# Plastic water trap in fume hood; 35 US\$; Captures 80% mercury

GMP, 2007; YTS, Kalimantan

- 35 out of 35 shops installed hood within 6 months (2006/07)
- Still in place in 2009



# Emissions Control

## Example: Retorts

- Captures mercury during amalgam burning
- Many simple designs available with local materials
- Can easily capture 95% or more of mercury in Amalgam



# Mercury Recycling Example: Re-activation

- 3\$ US electrolytic cell prevents miners from:
  - overusing mercury
  - throwing away “sick” mercury
  - buying new mercury to replace old
- Gets more gold
- Profitable at first use

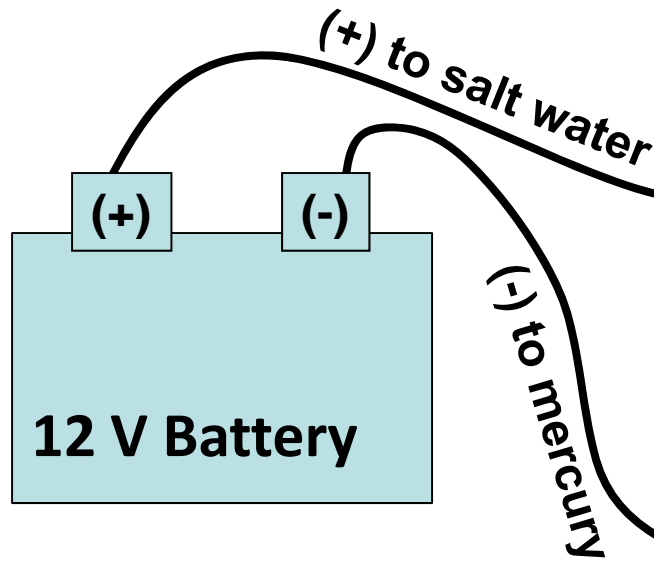

# Financial Solutions

- Using the gold market to incentivize change
  - (e.g., Fair Mined/ Fair Trade brands)



- Access to credit for investment in technology
- Tax incentives (exemptions, innovation credits (e.g. Canada's SR&ED))

# Policy Solutions

- Trade policy reform:
  - export bans / reducing primary mining to reduce supply and increase price;
  - gold import/export liberalisation to enable market incentives
- Mining policy reform, to recognize / incorporate/ formalize ASM systems, to enable education and assistance to miners
- Information sharing to help prioritize action where it is needed and measure progress

# Policy Example: Supply Restriction / Export Bans

- Restricting supply (export bans from major suppliers / reducing primary mining) will cause a rise in mercury price
  - This will incentivize mercury conservation to occur
  - Note: import restrictions and laws about mercury use have not been very effective; *more and better diligence everywhere* approach is wasteful
- Recycling/ re-use has already been embraced by some ASGM communities as profitable; this will be amplified if mercury prices increase
- Scarcity will make miners more receptive to information on how mercury can be sustainably reduced
- Treaty allows global coordination of supply restriction actions

# How can the Transition be Supported?

- The partnership and governments (as per UNEP GC decision) can identify priorities and viable mechanisms on a per country basis
  - Technical education
  - Community capacity building
  - Miner to miner exchange programs (poor ASM learns from good ASM)
  - **Pilot projects** – to test and refine approaches
  - Education and awareness built into existing rural development programs
  - Review and compare successful legal frameworks

# Who can be Involved?

- ASM communities and their local governments
- Multiple national government stakeholders
  - Mining
  - Environment
  - Health
  - Trade
  - Education
  - Treasury (federal gold reserves)
- Gold industry from bottom to top (producers, traders, buyers, nations heavily involved in gold mining)
- Jewellers and luxury goods market

# Opportunities Within the Treaty

- The treaty alone cannot fix the problem from a top down legal framework approach
  - It is a complicated poverty issue with an informal economy
- The treaty can create an enabling environment that will allow other mechanisms to operate to their maximum capacity
  - Awareness and information to set priorities: e.g. populating and updating the mercury watch database
  - Establishing a framework of goals that will allow businesses, NGO's, and local governments to effectively engage the ASM sector to enable profitable transition away from mercury
  - Fund selected pilot projects to test and refine approaches
  - Limit supply through export bans and reductions in primary mercury mining

# Reduction Scenarios

- If miners adopted mercury recycling measures
  - Fume hoods and retorts can reduce mercury consumption globally by a maximum of 25%
    - This is profitable
  - Learning how to re-activate used mercury could reduce mercury consumption by a maximum of 25%
    - This is profitable
- Elimination of whole ore amalgamation could reduce mercury consumption by 45% or more
  - Profitable but more complicated
  - More capital, more organisation, more processing sophistication

# Conclusions

- Challenges
  - Informal, extra-legal, sometimes illegal communities
  - Highly decentralized (thousands of sites; 70 countries)
  - Diversity of ores, processes, communities, policies
  - There will not be a silver bullet but can be a steady transition
- Solutions and Mechanisms
  - Technology Transfer and Innovation
  - Financial Incentives
  - Policy / Governance Innovation
  - Globally coordinated action, for both supply of mercury and demand for clean gold
- Approach: ***A Profitable Transition Away from Isolation and Mercury Use***